

Technical data sheet

Product features



Salamander digital 4 heating elements movable upper part automatic 400 V

Model	SAP Code	00010734
--------------	-----------------	----------



- Removable bottom shelf: Yes
- Continuously sliding upper part of the device with heating elements: Yes
- Automatic temperature control: Yes
- Stainless steel holder included for easy wall mounting: Yes
- Automatic switch off at the end of the cycle and acoustic signaling: Yes
- HOLD function for temperature maintenance: Yes
- Number of heating elements: 4 heating elements, 6 heating options

SAP Code	00010734	Power electric [kW]	6.000
Net Width [mm]	735	Loading	400 V / 3N - 50 Hz
Net Depth [mm]	580	Removable bottom shelf	Yes
Net Height [mm]	520	Number of heating elements	4 heating elements, 6 heating options
Net Weight [kg]	65.00		

Technical data sheet

Technical drawing



Salamander digital 4 heating elements movable upper part automatic 400 V

Model	SAP Code	00010734
--------------	-----------------	----------

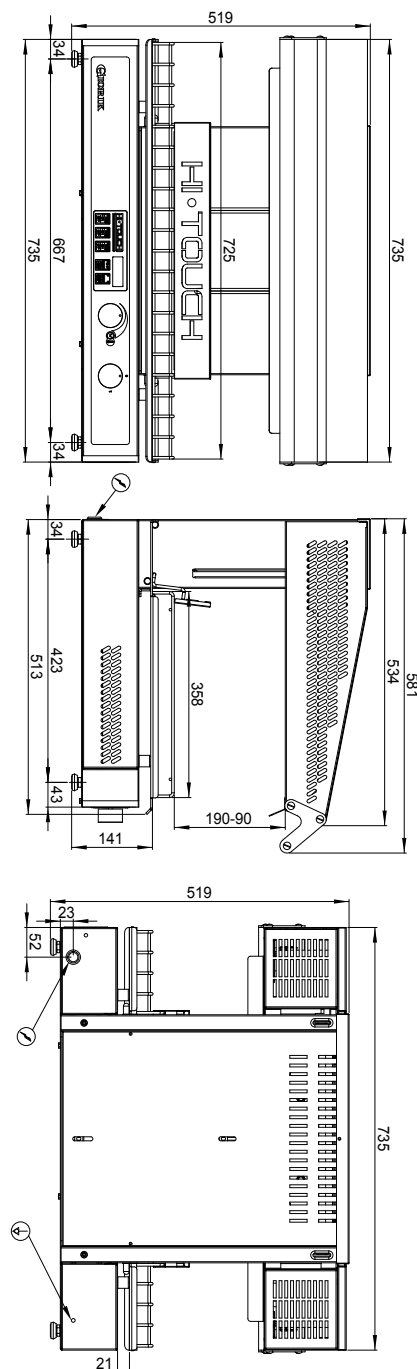

Technical data sheet

Product benefits



Salamander digital 4 heating elements movable upper part automatic 400 V

Model

SAP Code

00010734

1

Vermiculite heating segment cover

immediate barrier-free penetration of heat and light from the heating segments
very durable material

- intensive heat treatment of food

2

Special heating elements,

instant thermal run-up

- salamander does not need to be continuously switched on, food is cooked in real time, no waste heat is generated in the kitchen

3

Sliding system

a sliding system enabling a smooth shift of the lift and setting the required distance from the food

- convenient control without the need to exert force to adjust the distance needed to cook the food

4

Individual zone control

control elements enabling switching on individual zones of the device

saves energy and extends its life

- energy saving
- allows for the preparation of different sized foods

5

Stainless steel construction

construction material is high quality stainless steel
ensuring long life
high hygiene standard

- safe food preparation; long service life; easy cleaning

6

Wall mount

construction allowing hanging on a wall or structure

- space saving in the kitchen; easy access

7

Automatic shutdown

automatic shutdown at the end of the set cycle
acoustic signal

- Prevents food spoilage

Technical data sheet

Technical parameters



Salamander digital 4 heating elements movable upper part automatic 400 V

Model	SAP Code	00010734
-------	----------	----------

1. SAP Code:

00010734

2. Net Width [mm]:

735

3. Net Depth [mm]:

580

4. Net Height [mm]:

520

5. Net Weight [kg]:

65.00

6. Gross Width [mm]:

830

7. Gross depth [mm]:

650

8. Gross Height [mm]:

710

9. Gross Weight [kg]:

69.00

10. Device type:

Electric unit

11. Material:

Stainless steel

12. Device heating type:

Infrared emitter

13. Power electric [kW]:

6.000

14. Loading:

400 V / 3N - 50 Hz

15. Maximum device temperature [°C]:

230

16. Control type:

Digital

17. GN / EN size in device:

GN 1/1

18. Removable bottom shelf:

Yes

19. Continuously sliding upper part of the device with heating elements:

Yes

20. Automatic temperature control:

Yes

21. Stainless steel holder included for easy wall mounting:

Yes

22. Automatic switch off at the end of the cycle and acoustic signaling:

Yes

23. HOLD function for temperature maintenance:

Yes

24. Number of heating elements:

4 heating elements, 6 heating options
– 4 topné elementy, 6 variant ohřevu

Technical data sheet

Technical parameters



Salamander digital 4 heating elements movable upper part automatic 400 V

Model	SAP Code	
		00010734

25. Cross-section of conductors CU [mm²]:

1

– Výkon (kW): 3,7-5 (230 V); 6,4-8,7 (400 V)